



RYA National Hornet European Championships

6th – 9th August 2016

Under the Burgee of
Herne Bay Sailing Club



Herne Bay Sailing Club
Family Sailing at its best



The Organising Authority (OA) is the Herne Bay Sailing Club in conjunction with the National Hornet Class Association

NOTE:

Trolleys

Please ensure all trolleys are left above the high water line on the beach or in your allocated space on the promenade. This is a public beach and promenade. Care must be taken not to compromise the Club's position with the local community, nor injure any third party.

SAILING INSTRUCTIONS

1. RULES

- 1.1. The regatta will be governed by the rules as defined in the Racing Rules of Sailing 2013-2016.
- 1.2 The Equipment Rules of Sailing will apply.
- 1.3 Part 5, Section B of *The Racing Rules of Sailing*, as well as rules 44.1 and 63.1 will be changed in the Sailing Instructions to permit Protest Arbitration.
- 1.4 Adequate personal buoyancy shall be worn by all competitors at all times whilst afloat – except for a short period whilst changing clothing. Flag 'Y' will not be displayed; this changes RRS rules 40.1 and Race Signals 'Y'.

2. NOTICES TO COMPETITORS

Notices to competitors will be posted on the official notice board(s) located at the Race Office in the Herne Bay Sailing Club House.

3. CHANGES TO SAILING INSTRUCTIONS

Any change to the Sailing Instructions will be posted before 0900 on the day it will take effect, except that any change to schedule of races will be posted by 2000 on the day before it will take effect.

4. SIGNALS MADE ASHORE

- 4.1. Signals made ashore will be displayed at on the gantry on top of the HBSC Clubhouse
- 4.2. When flag AP is displayed ashore, '1 minute' is replaced with 'not less than 45 minutes' in the race signal AP

5. SCHEDULE OF RACES

5.1. The schedule of races:

| <u>Date</u> | <u>Tide: BST</u> | <u>Race/event</u> | <u>Time/warning</u> |
|---------------------|------------------|----------------------|---------------------|
| Fri 5 th | | Equipment inspection | 17.30 – 19.30 |

| | | | |
|------------------------|-------|---|---|
| Sat 6 th | 15.28 | Equipment Inspection Registration Competitor Briefing Race 1 Race 2 | 09:00 – 11.30 09.30 – 11.30 12.00 14.30 asap after race 1 |
| Sunday 7 th | 16.03 | Race 3 – start Race 4 Race 5 | 11.00 asap after race 3 asap after race 4 |
| Monday 8 th | 16.38 | Race 6 – start Race 7 Race 8 | 11.00 asap after race 6 asap after race 7 |
| Tues 9 th | 17.13 | Race 9 Race 10 Prize giving | 11.00 asap after race 9 asap after racing |

5.2. 10 Races are scheduled for the European Championship.

5.3. To alert boats that a race or sequence of races will begin soon, the orange starting line flag will be displayed with one long sound signal at least five minutes before a warning signal is made. Where more than one race is scheduled on a day the second race will start as soon as possible following the completion of the previous race.

5.4 Races not completed as scheduled may be sailed at a later time or day. Extra races may be sailed provided that the championship does not become more than one race ahead of schedule. No more than 4 races will be sailed per day.

5.5 On the last day of the regatta no warning signal will be made after 15.30.

6. CLASS FLAGS

The Class Flag will be the Third Substitute Flag.

7. RACING AREA

The racing area will be in the open sea, north of HBSC

8. THE COURSES

8.1. The diagrams in Appendix A show the course including the approximate angles between legs, the order in which marks are to be passed, and the side on which each mark is to be left.

8.2. No later than the warning signal, the approximate compass bearing of the first leg may be displayed on the race committee signal boat.

9. MARKS

- 9.1. Marks 1, 2, 3 and 4 will be Orange cylindrical inflatable pillar buoys.
- 9.2. New marks, as provided in instruction 12.1 will be Yellow sphere inflatable buoys.
- 9.3 The starting and finishing marks will be a yellow spherical buoy.
- 9.4 A race committee boat signaling a change of a leg of the course is a mark as provided in instruction 12.3

10. AREAS THAT ARE OBSTRUCTIONS

There is a potential hazard in our waters which is an outfall marker and is currently surrounded by lobster pots so needs a wide berth.

11. THE START

- 11.1. Races will be started using Rule 26 with the warning signal made five minutes before the starting signal.
- 11.2. The starting line will be a line between the main mast displaying an orange flag on the Race Committee Signal Boat and either:
 - the mast displaying an orange flag on a race committee line boat (at the port end of the line); or
 - the starting mark.
- 11.3. Start line limit marks may be laid near the race committee signal boat and the race committee line boat. These marks shall rank as starting marks and boats shall pass between them when starting. After the preparatory signal no part of a boat shall pass between the starboard-end limit mark and any part of the race committee signal boat or the port-end limit mark and any part of the race committee line boat. Failure for these marks to be on the line shall not constitute grounds for redress under rule 62.1(a).
- 11.4. A boat starting later than 10 minutes after her starting signal will be scored Did Not Start without a hearing. This changes rule A4.

12. CHANGE OF THE NEXT LEG OF THE COURSE

- 12.1. To change the next leg of the course, the Race Committee will lay a new mark (or move the finishing line) and remove the original mark as soon as practicable. The change will be signaled before the leading boat has begun the leg although the new mark may not yet be in position.
- 12.2. When in a subsequent change a new mark is replaced, it will be replaced by an original mark.
- 12.3. Except at a gate, boats shall pass between the race committee boat signaling the change of the next leg and the nearby mark, leaving the mark to port and the race committee boat to starboard. This changes rule 28.

13. THE FINISH

- 13.1. The finishing line will be between a staff displaying an orange flag on the race committee vessel and the finishing mark.

14. PENALTY SYSTEM

A boat that has taken a penalty or retired under Rule 31 or Rule 44.1 shall complete an acknowledgment form at the Race Office within the protest time limit.

15. TIME LIMITS

- 15.1. Time limits and target times are as follows:

| <u>Time limit</u> | <u>Mark 1 time limit</u> | <u>Target time</u> |
|-------------------|--------------------------|--------------------|
| 90 minutes | 45 minutes | 60 - 75 minutes |

If no boat has passed mark 1 within the mark 1 time limit the race will be abandoned. Failure to meet the target time will not be grounds for redress. This changes rule 62.1(a).

- 15.2. Boats failing to finish within 30 minutes after the first boat sails the course and finishes will be scored as per SI 15.3. This changes rules 35, A4 and A5.

- 15.3. At the time point in 15.2 the Race Officer will instruct an official boat to move back down the course and record the positions of those boats still on the course as they pass them. The positions recorded shall not be grounds for redress; this changes RRS 62.1(a).

16. PROTESTS AND REQUESTS FOR REDRESS

- 16.1. The Exoneration Penalty and the Advisory Hearing and RYA Arbitration of the RYA Rules Disputes Procedures will be available. Details of the Procedures are posted on the Official Notice Board.
- 16.2. Protests forms are available at the Race Office. Protests and requests for redress or reopening shall be delivered there within the appropriate time limit.
- 16.3. The protest time limit is 45 minutes after the last boat has of the fleet coming ashore after the days racing.
- 16.4. Notices will be posted no later than 30 minutes after the protest time limit to inform competitors of hearings in which they are parties or named as witnesses. Hearings will be held in the protest room located at HBSC Starters Cabin beginning at the time posted.
- 16.5. Notices of protests by the race committee or protest committee will be posted to inform boats under rule 61.1(b).
- 16.6. Breaches of instructions 18, 21, 23, 24 will not be grounds for a protest by a boat. This changes rule 60.1(a). Penalties for these breaches and for class rule breaches may be less than disqualification if the protest committee so decides.

16.7. On the last day scheduled day of racing a request for reopening a hearing shall be delivered;

- within the protest time limit if the party requesting reopening was informed of the decision the previous day
- no later than 30 minutes after the party requesting reopening was informed of the decision on that day.

This changes rule 66.

16.8 On the last scheduled day of racing a request for redress shall be delivered no later than 30 minutes after the decision was posted. This changes rule 62.2.

16.9 The use of team racing tactics will not be tolerated. If the Race Committee or Protest Committee determine that the use of team racing tactics may have significantly influenced the outcome of the race they shall order that race to be abandoned and, if possible, re-sailed excluding the participation of the infringing boat(s). This modifies rule RRS36. If the race is not re-sailed, the infringing boat(s) shall be subject to protest and disqualification.

17. SCORING

17.1 Three (3) races shall be completed to constitute a series.

17.2 When fewer than four (4) races have been completed, a boat's series score will be the total of her race scores.

17.3 When from four (4) to six (6) races have been completed, a boat's series score will be the total of her race scores excluding her worst score.

17.3 When from seven (7) or more races have been completed, a boat's series score will be the total of her race scores excluding her two (2) worst scores.

18. SAFETY REGULATIONS

18.1. A boat that retires from a race shall, where possible, notify a Race Committee Vessel before leaving the racing area and shall immediately on returning to shore comply with Sl's 14 and 18.2.

18.2. A tally system is to be used for the safety of the competitors for the duration of the championship.

Each member of a boat's crew shall individually tally out before racing and individually tally in immediately on returning to shore after racing.

The time limit for tallying in is within 60 minutes of the last boat finishing the last race of the day.

Boats whose crew(s) forget to tally out shall report to the Race Committee Boat prior to the warning signal. Such boats will be liable to a penalty of £10 payable to the RNLI.

Boats whose crew(s) fail to tally out and/or tally in (and have not complied with the above) will be subject to disqualification without a hearing from all races held that day. This adds to the exceptions within RRS63.1. The Race

Officer has the discretion to commute this punishment to a fine payable to the RNLI. This adds to the exceptions within Rule 63.1.

19. REPLACEMENT OF CREW OR EQUIPMENT

- 19.1. Substitution of competitors shall not be allowed without prior written approval of the Race Committee. Permission to substitute crew will only be granted in cases of injury or illness or serious unforeseen personal circumstances.
- 19.2. Substitution of damaged or lost equipment will not be allowed unless authorised by the Race Committee. Requests for substitution shall be made to the committee at the first reasonable opportunity

20. EQUIPMENT AND MEASUREMENT CHECKS

- 20.1. Boats may be inspected at any time for compliance with the class rules and sailing instructions.
- 20.2. Before a boat is eligible to race, her current, valid measurement certificate must be presented at the Race Office or its existence verified.
- 20.3. All boats shall sail under their registered class number. Only pre-measured sails that have been inspected for the event shall be used. 2 Jibs, 2 Mains and 2 Spinnakers only may be presented for registration.
- 20.4. Subject to the written permission of the Race Committee a boat chartered or loaned for the event may declare at the time of entry or registration a sail number to be displayed on all sails used in the regatta which may be different from the number of the boat as stated on the measurement certificate provided that this declared number shall not be the sail number of any other boat competing in the regatta.
- 20.5. Each boat, with her sails and equipment, shall be available for equipment inspection as stated in the schedule 5.1.
- 20.6. The first three boats of each race may be weighed after the last race of each day. Boats found to be underweight will be penalized by a 5-point penalty per race sailed that day. It is the responsibility of each competitor to ensure his boat is the correct weight prior to the start of the championship.

21. OFFICIAL BOATS

All race committee vessels, including mark boats will display identification as described on the official notice board.

22. SUPPORT BOATS

- 22.1 Support boats shall register with the organising authority at the times prescribed for registration and shall declare the names and sail numbers of

the competitors with whom they are associated. Team and support boats shall be conspicuously identified by the country name, national letters or national flag of the team(s) they represent.

- 22.2 Team leaders, coaches and other support personal shall remain more than 200 metres from the course area, and shall not communicate with competitors while they are racing in any way verbally or with signals. They shall not cause wash to spread across the race area. The course area is defined as the area bounded by all the racing marks and any boat racing. This SI does not apply during rescue operations if asked to assist.
- 22.3 Then penalty for failing to comply with this SI may be the disqualification of boats associated with the infringing personnel in that race, or any other penalty that the protest committee may decide.
- 22.4 Support boats may be requested to assist the race committee with rescue duties and shall monitor VHF channel 37 at all times whilst afloat.

23. TRASH DISPOSAL

Trash may be placed aboard support or official boats.

24. RADIO COMMUNICATION

Except in an emergency, a boat shall neither make radio transmissions while racing nor receive radio communications not available to all boats. This restriction applies to mobile telephones and similar devices.

25. PRIZES

Prizes will be given as per the list on the official notice board.

26. DISCLAIMER OF LIABILITY

Competitors participate on the regatta entirely at their own risk. See rule 4, Decision to Race. The organizing authority will not accept any liability for material damage or personal injury or death sustained in conjunction with or prior to, during, or after the regatta.

27. RISK STATEMENT

Rule 4 of the RRS states “the responsibility for a boat’s decision to participate in a race or to continue to race is hers alone”.

Sailing is by its nature an unpredictable sport and therefore inherently involves an element of risk. By taking part in the event, each competitor agrees and acknowledges that:

- (a) They are aware of the inherent element of risk involved in the sport and accept responsibility for the exposure of themselves, their crew and their boat to such inherent risk while taking part in the event;
- (b) They are responsible for the safety of themselves, their crew, their boat and other property whether afloat or ashore;
- (c) They accept responsibility for any injury, damage or loss caused by their own actions or omissions;

- (d) Their boat is in good order, equipped to sail in the event and they are fit to participate;
- (e) The provision of a race management team, patrol boats and other officials and volunteers by the event organiser does not relieve them of their own responsibilities;
- (f) The provision of patrol boat cover is limited to such assistance, particularly in extreme weather conditions, as can be practically provided in the circumstances;

28. INSURANCE

Each participating boat shall be insured with valid third-party liability insurance with a minimum cover of £3,000,000 per incident or the equivalent.

29. TELEVISION & PHOTOGRAPHERS' RIGHTS

Competitors give absolute right and permission for video footage or photographs of themselves or their boat to be published in any media for press, editorial or advertising purposes.

Appendix – Course Diagrams

5 Course A

- 5.1 Warning - diagrams are not to scale, proportions and angles are not accurate. Note that the committee boat will be positioned at approximately 1/3rd up the windward leg
- 5.2 Course diagram

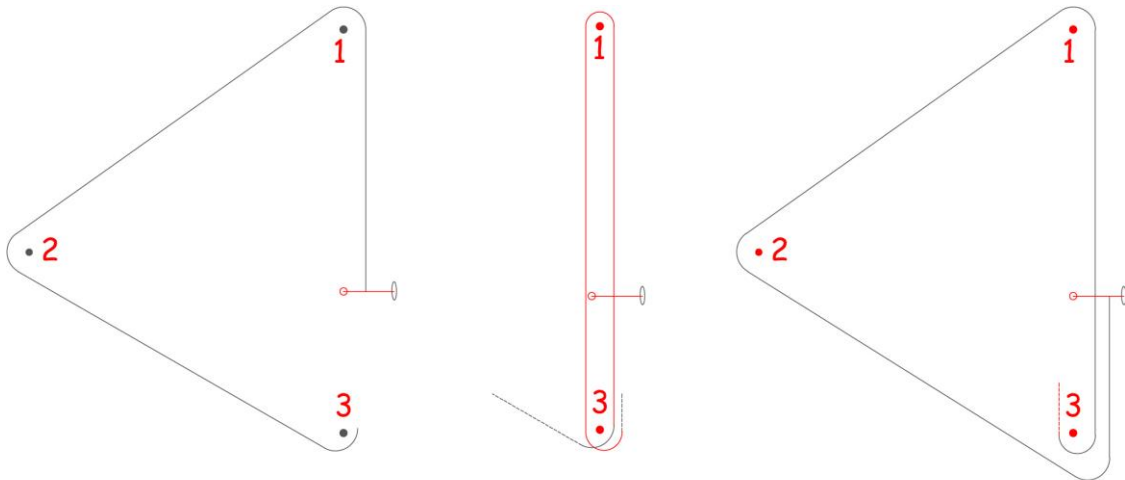

Round 1

Round 2

Round 3

Round 1 = Start Line – 1 port – 2 port – 3 port – Gate

Round 2 = 1 port – 3 port Competitors must not pass through the start/finish gate on an off-wind leg

Round 3 = 1 port – 2 port – 3 port - Finish Line

6 Course B

6.1 Warning - diagrams are not to scale, proportions and angles are not accurate. Note that the committee boat and start line buoy will be positioned to leeward of the leeward leg

6.2 Course diagram

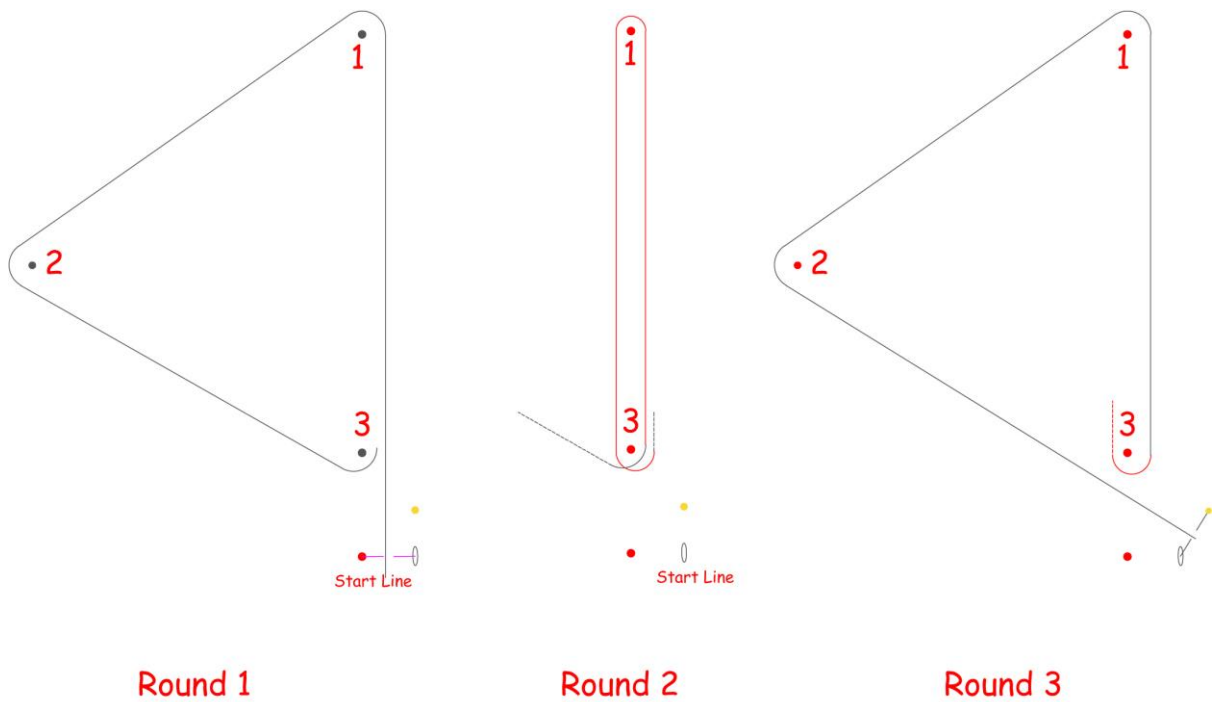

Round 1 = Start Line – 1 port – 2 port – 3 port
Round 2 = 1 port – 3 port
Round 3 = 1 port – 2 port – 3 port - Finish Line